

# 98780 CE Handbook

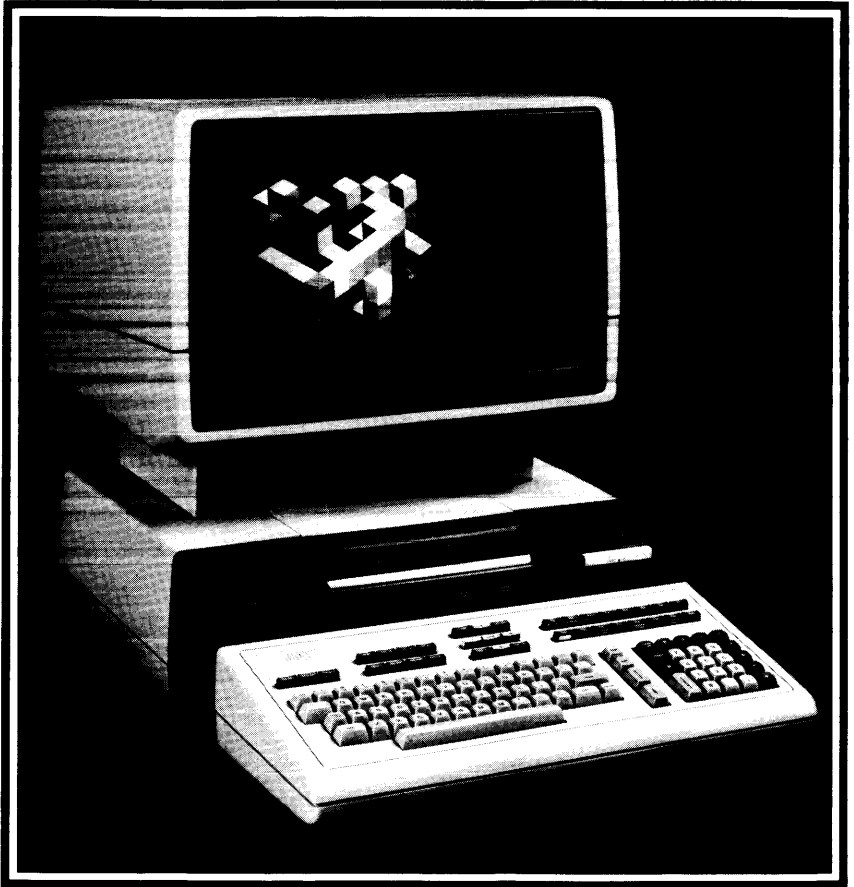

# 98780 CE Handbook

© Copyright 1982, 1983, Hewlett-Packard Company

This document contains proprietary information which is protected by copyright. All rights are reserved. No part of this document may be photocopied, reproduced or translated to another language without the prior written consent of Hewlett-Packard Company. The information contained in this document is subject to change without notice.

**Restricted Rights Legend**

Use, duplication, or disclosure by the Government is subject to restrictions as set forth in paragraph (b)(3)(B) of the Rights in Technical Data and Software clause in DAR 7-104.9(a).

**Hewlett-Packard Company**  
3404 East Harmony Road, Fort Collins, Colorado 80525

Chapter 1  
98780 Product Information

Chapter 2  
98780 Environmental Installation FM

Chapter 3  
98780 Configuration

Chapter 4  
98780 Troubleshooting

Chapter 5  
98780 Diagnostics

Chapter 6  
98780 Adjustments

Chapter 7  
98780 Peripherals

Chapter 8  
98780 Replacement Parts

Chapter 9  
98780 Diagrams

Chapter 10  
98780 Reference

Chapter 11  
98780 Service Notes

## Printing History

New editions of this manual will incorporate all material updated since the previous edition. Update packages may be issued between editions and contain replacement and additional pages to be merged into the manual by the user. Each updated page will be indicated by a revision date at the bottom of the page. A vertical bar in the margin indicates the changes on each page. Note that pages which are rearranged due to changes on a previous page are not considered revised.

The manual printing date and part number indicate its current edition. The printing date changes when a new edition is printed. (Minor corrections and updates which are incorporated at reprint do not cause the date to change.) The manual part number changes when extensive technical changes are incorporated.

October 1982...First Edition

December 1983...Second Edition. Updated pages: ii, 1-2, 8-3, 9-1.

### Warranty Statement

Hewlett-Packard products are warranted against defects in materials and workmanship. For Hewlett-Packard Fort Collins Systems Division products sold in the U.S.A. and Canada, this warranty applies for ninety (90) days from the date of delivery.\* Hewlett-Packard will, at its option, repair or replace equipment which proves to be defective during the warranty period. This warranty includes labor, parts, and surface travel costs, if any. Equipment returned to Hewlett-Packard for repair must be shipped freight prepaid. Repairs necessitated by misuse of the equipment, or by hardware, software, or interfacing not provided by Hewlett-Packard are not covered by this warranty.

HP warrants that its software and firmware designated by HP for use with a CPU will execute its programming instructions when properly installed on that CPU. HP does not warrant that the operation of the CPU, software, or firmware will be uninterrupted or error free.

HEWLETT-PACKARD MAKES NO WARRANTY OF ANY KIND WITH REGARD TO THIS MATERIAL, INCLUDING, BUT NOT LIMITED TO, THE IMPLIED WARRANTIES OF MERCHANTABILITY AND FITNESS FOR A PARTICULAR PURPOSE. Hewlett-Packard shall not be liable for errors contained herein or for incidental or consequential damages in connection with the furnishing, performance or use of this material.

\* For other countries, contact your local Sales and Support Office to determine warranty terms.

# Chapter 1

## Product Information

### 98780A Specifications

#### Environmental Range

Operating Temperature:	+5°C to +40°C ambient
Storage Temperature:	-40°C to +65°C
Ambient Humidity:	<80%

#### Size/Weight

Height:	26.5 cm
Width:	41 cm
Depth:	38 cm
Net Weight:	14 kg

#### Display Features

Cathode Ray Tube:	30.5 cm (12 inch) diagonal
Scan:	Non-interlaced raster scan
Refresh Rate:	60 Hz
Vertical Scan Rate:	60 Hz

#### Alphanumeric Display

Alpha Raster Size:	236 mm x 149 mm (720 dots x 455 dots)
Screen Capacity:	2400 characters (30 lines of 80 characters)
Character Font:	7 dot x 9 dot in a 9 x 15 matrix
Character Size:	2.3 mm wide x 3.0 mm high (7 x 9 character)
Standard Character Set:	128 ASCII characters
Additional Character Sets:	European, Katakana
Cursor:	Blinking underline, blinking back arrow
Highlighting:	Inverse video, blinking, underline

#### Graphics Display

Graphics Raster Size:	184 mm x 149 mm (560 dots x 455 dots)
Matrix Size:	560 dots x 455 dots
Graphics Memory:	16 k-words of read/write memory
Graphics Cursor:	Full-screen and small crosshair, blinking underline
Resolution:	Dots are spaced .33 mm center to center
Vector Drawing Speed:	254 metres per second

## Options and Configurations

The 98780A is available as either a part of the 9845B #2XX or as part of the 98404A Upgrade Kit.

98404A	Upgrade Kit	(Upgrades 9845B to High Performance CRT)
98405A	Upgrade Kit	(Upgrades 9845B to High Performance CRT and fast processor)
98775A	Light Pen	(Also available as 9845B #775 or 98404A #775)

Available character sets are:

9845B	ASCII/European	(Also 98404A standard)
9845B #840	Katakana	(Also 98404A #041)

## Related Documentation

98780-90030	Service Manual
09845-93050	Monochromatic Graphics Programming Manual
09845-92005	Owner's and System Exerciser Manual
09845-90039	98780 CE Handbook

## Product Support Package

The 98780A requires no special tools to service other than those which are provided for servicing the 9845B.

## Safety

---

### WARNING

LETHAL VOLTAGES ARE PRESENT INSIDE THE 98780A. REFER TO THE GENERAL SAFETY GUIDELINES IN THE 98780A SERVICE MANUAL.

---

## Modifications for 9000 Series 500 Model 20

The 98780A display unit is used with the 9000 computers and must be modified by the addition of a printed circuit board. This board is installed inside its own housing that is attached to the under side of the display housing. This board forms the interface between the 98780A and the 9000 computer. The service information is contained in the Service Manual for the 9000 computers. (HP part number 09020-90038)

# Chapter 2

## Environmental/Installation/ Preventive Maintenance

### Installation

The display assembly fits into place over the mainframe support legs.

---

**CAUTION**

---

THE 98780A RELIES ON THE MAINFRAME TOP COVER FOR WEIGHT SUPPORT. THE MAINFRAME TOP COVER MUST BE INSTALLED BEFORE INSTALLING THE 98780A.

---

Pull out the locking rods (one on the back of each support leg) and place the 98780A over the mainframe support legs as shown in Figure 1-1. Push in on the locking rods to lock the 98780A to the mainframe.

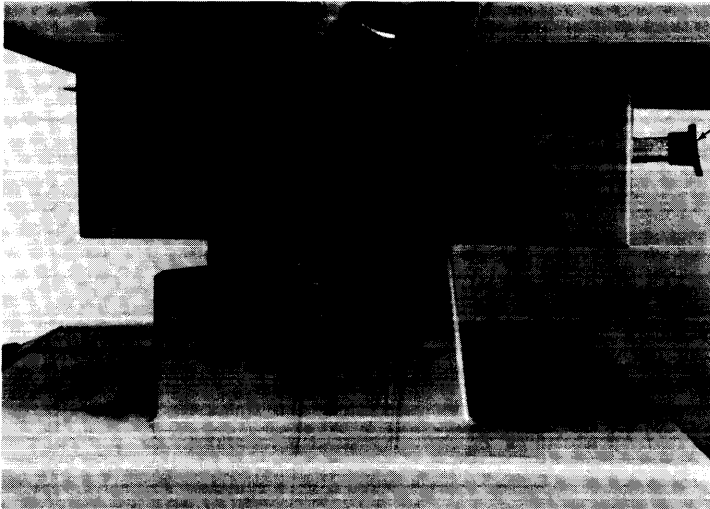

98780A Installation





# Chapter 3

## Configuration

### Base Configuration

The following assemblies must be installed in the 9845B base to support the 98780A. (These parts are included in the 98404A Upgrade Kit.)

98780-65501	Enhanced Graphics ROM
1818-1591	Mainframe ROM for Enhanced Graphics ROM
and 1818-1592	Mainframe ROM for Enhanced Graphics ROM
98770-66534	Alpha Control Assembly (Replaces 09845-66503 in base.)

Refer to the 9845B Base CE Handbook Chapter for the locations of these parts.

### Interfacing

The 98780A interfaces to the 9845B base via the Alpha Control Assembly (98770-66534) and the Graphics Interface Assembly (09845-66504). Alpha information is stored in block 0 read-write memory, and is refreshed to the display via the IDA bus. Graphics information is transferred via the I/O bus to the display, where it is interpreted and entered into the display memory.

### Status Word

The Status Word may be obtained by executing the following instructions:

```
STATUS 13;A
DISP A
```

The result is a decimal integer which may be converted to binary and interpreted as shown below.

Bit	15	14	13	12	11	10	9	8	7	6	5	4	3	2	1	0
	0	0	GR STAT	0	1	0	1	0	1 EN	DMA EN	0	0	OPT SR	G SR	SK	LP

Bit	Description
13	Graphics status
11,9	Identification bits
7	Interrupt enable
6	DMA enable
3	Option service request
2	Graphics service request
1	Softkey service request
0	Light pen service request

## 3-2 98780 Configuration

# Chapter 4

## Troubleshooting

### Initial Checks

<b>Check</b>	<b>Action</b>
Is the base operating? (Try PRINTER IS 0 PRINT "HELLO")	Yes - Proceed with Initial Checks. No - Fix base.
Is there any display?	Yes - Proceed to Problem Charts. No - Proceed with Initial Checks.
Still no display?	Proceed to Problem Charts.
Adjust intensity control. Press control-stop. Is there a cursor?	

## Problem Charts

The following charts attempt to list some of the more common problems and identify the most probable assemblies associated with that problem. The numbers in the charts indicate the probability; i.e., a "1" is the most probable cause and a "4" is the least probable cause.

### Raster Problem Chart

Symptom	Probable Cause				
	A11	A12/ A14	CRT/ Yoke	HV XFMR	Heat sink
No display	2	1	4	3	
Improper focus	1		2	3	
Improper intensity	1	2	3	4	
No high voltage	4	3		2	1
No raster deflection		1	3		2
Distorted raster shapes		1	2		3

### Alpha Problem Chart

Symptom	Probable Cause			
	A21	A31/A32	A34	A11
No alpha display	2	3	1	4
Improper or incorrect characters	2	3	1	
Characters missing (every other line) or incorrect	2		1	
Incorrect highlighting	1		2	
Alpha cursors missing or incorrect	1		2	
No alpha blanking	1			

### Graphics Problem Chart

Symptom	Probable Cause	
	A31/A32	A51/A52
No graphics display	1	2
Extra or missing vectors	2	1
Extra or missing arcs	2	1
Improper or no area fill	2	1
Improper line type or no line type control	2	1
Random or repetitive dots either missing or always on display	2	1
Intermittent display dots	2	1
Can't read or write into graphics memory	1	2
Graphics cursors missing or incorrect		1

## Voltage Checks

The mainframe power supply voltages can be checked in the 98780A. Figure 4-1 shows the test points and the corresponding voltages.

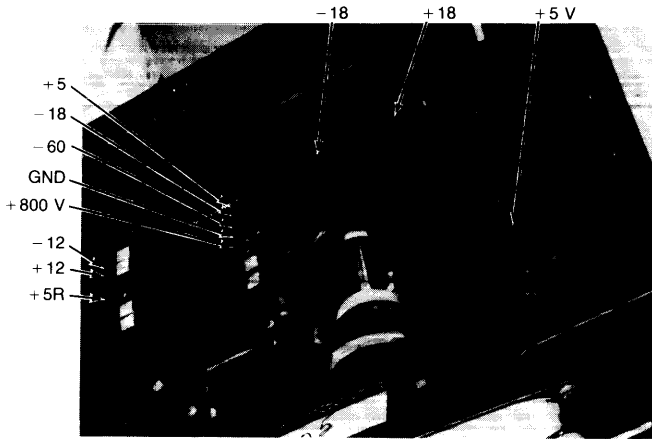

Figure 4-1. Voltage Test Points

Table 4-1 shows the distribution of the various voltages in the 98780A.

Table 4-1. Voltage Distribution

Voltage	Comes from	Used
+ 18 volts	Mainframe Power Supply	98780-66513 Heatsink, A12/A14 Deflection A21 Display Logic, 98775-66504 Light Pen, A11 CRT Drive
- 18 volts	Mainframe Power Supply	98780-66513 Heatsink, A11 CRT Drive A12/A14 Deflection, A21 Display Logic 98775-66504 Light Pen
+ 12 volts	Mainframe Power Supply	A31 I/O, A11 CRT Drive, A12/A14 Deflection, A51/A52 Graphics
- 12 volts	Mainframe Power Supply	A31 I/O, A12 Deflection, A51/A52 Graphics
+ 5 volts	Mainframe Power Supply	All PC assemblies except 98780-66513 Heatsink
+5R	Regulator on A12/A14	A12/A14 Deflection
+ - 15 volts	Regulator on A12/A14	A12/A14 Deflection

#### 4-4 98780 Troubleshooting

# Chapter 5

## Diagnostics

### Display Tests

Display tests for the 98780A are found on the following cartridges:

- 9845B/C System Exerciser Cartridge - 09845-92041, Rev. C
- Test Binary Cartridge - 09845-91031, Rev. C

The tests on the Test Binary Cartridge are essentially the same as the tests for the 98770A color display with some additions. Procedures can be found in the 98770A CE Handbook Chapter.

The tests on the 9845B/C System Exerciser Cartridge specifically test the features on the 98780A. These tests are described here.

To load the tests from the 9845B/C System Exerciser Cartridge, latch the AUTOST key and switch the power on or press LOAD "AUTOST:T15" EXECUTE. Answer the questions that appear and select ENHGR when the test choices appear.

ENHGR runs the complete sequence of tests automatically.

Selecting ENHGR, MENU will give you the following test menu.

The display tests are listed and described in the order they are performed in the Auto Cycle mode.

Here is a summary of the re-defined keys and the tests they initiate.

Key	Test	Page
A	Alphanumerics	5-4
B	Full Line Buffer	5-2
E	Exit, return to main program	
F	Focus	5-2
G	Grid	5-4
I	Video Intensity	5-3
K	Soft Keys	5-2
L	Linearity	5-2
M	Graphics memory test	5-8
P	Light pen test	5-8
R	Raster	5-7
S	"B" Pattern	5-7
T	Change cursor type	5-7
V	Vectors	5-5
X	Auto cycle	5-8

## **F Focus Alignment Pattern**

Press F; “%” characters appear on the display. Check the characters to ensure they are clear and readable. If necessary, remove the top covers and adjust the focus control to achieve the best overall character focus (refer to Chapter 4 for adjustment procedures). It may not be possible to achieve perfect focus in all areas of the display.

## **L Linearity**

Press L; various “+” characters appear in a pattern. This test is used to check linearity at the factory. It is not intended for field use.

## **B Full Line Buffer**

Press B; the CRT displays:

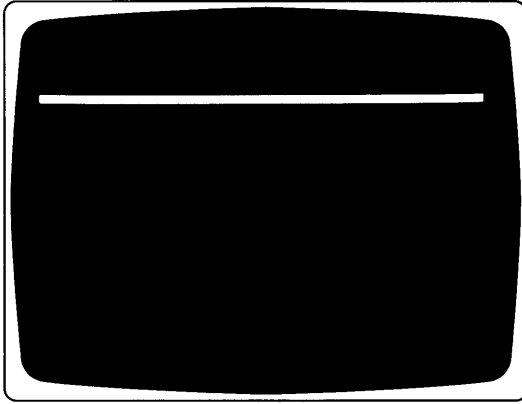

This test checks the 80-character line buffers on the A34 assembly (left leg), plus the ability to display information.

## **K Soft Keys**

Press K; then press each soft key on the lower CRT bezel. A display appears above the key when it is pressed to indicate the operation of the key.



## I Video Intensity

Press I; the following display appears to show all the various display intensities (video mixer test).

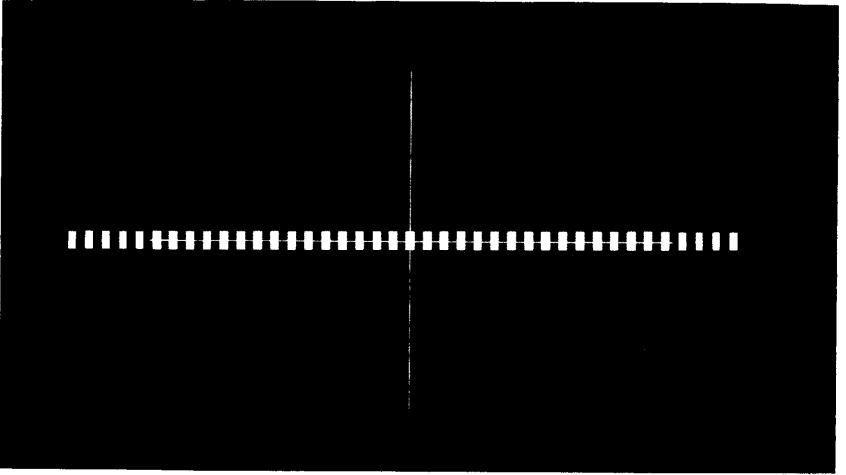

Press continue, the large square of the previous display becomes bright (light pen bit test).

Press continue to select another test.

## A Alpha Test

Press A; the alphanumeric display is on.

Press continue; the alphanumeric display is off (blank display).

Press continue; the alphanumeric display is on and the alternate cursor (back arrow) is displayed.

Press continue; the character set is displayed. The standard ASCII character set is shown below.

```

@A B C D E F G H I J K L M N O P Q R S T U V W X Y Z [ \ ] ^ _ ` a b c d e f g h i j k l m n o p q r s t u v w x y z { | } ~
! " # $ % & ' ( ) * + , - . / : ; < = > ? [ \ ] ^ _ ` a b c d e f g h i j k l m n o p q r s t u v w x y z { | } ~
@A B C D E F G H I J K L M N O P Q R S T U V W X Y Z [ \ ] ^ _ ` a b c d e f g h i j k l m n o p q r s t u v w x y z { | } ~
! " # $ % & ' ( ) * + , - . / : ; < = > ? [ \ ] ^ _ ` a b c d e f g h i j k l m n o p q r s t u v w x y z { | } ~

```

```

[No Highlight]
[Blinking Cursor]
[Inverse Video]
[Blinking Character]
[Underscore]

```

Press continue to select another test.

## G Grid

Press G; the grid shown below is displayed.

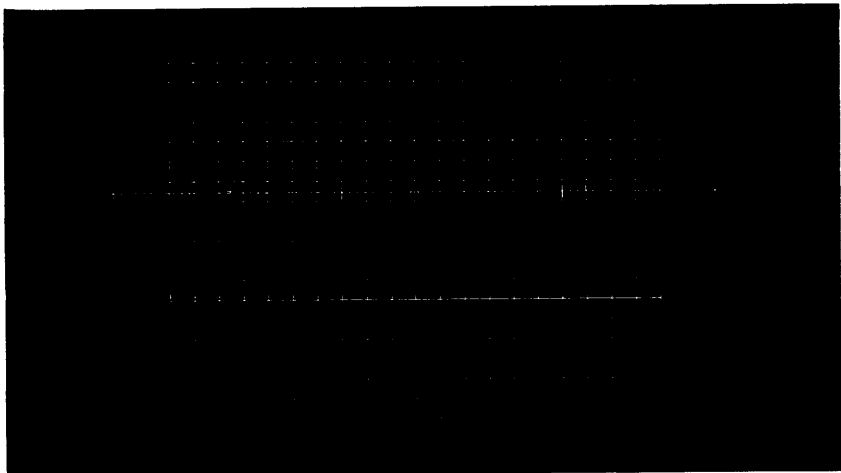

Press continue to select another test.

## V Vector Test

Press V; the various linetypes are displayed. See the following photo.

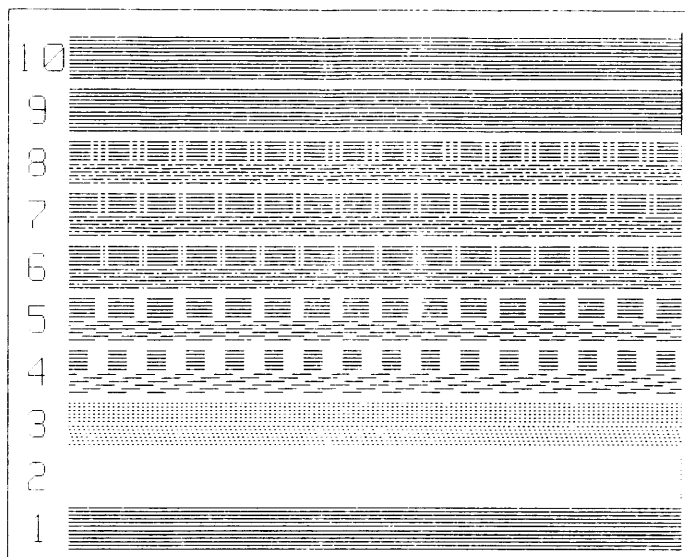

Press continue; the following display appears. This demonstrates the vector drawing ability.

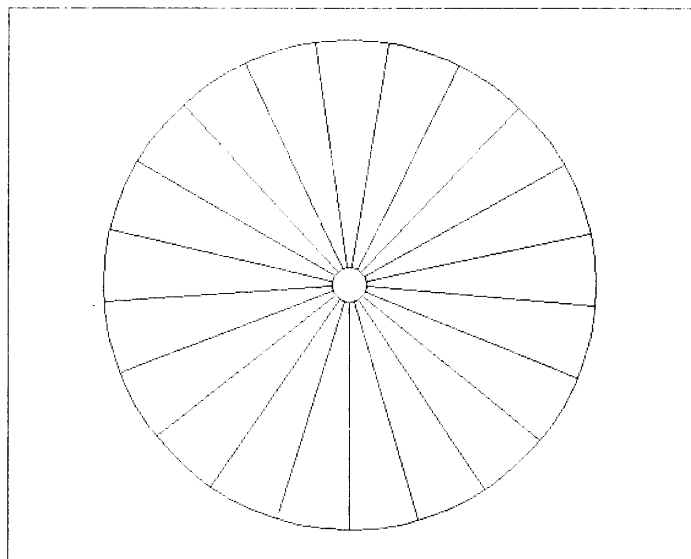

Press continue; the vectors drawn in the previous display are erased.

5-6 98780 Diagnostics

Press continue; arcs are drawn in the next display shown below.

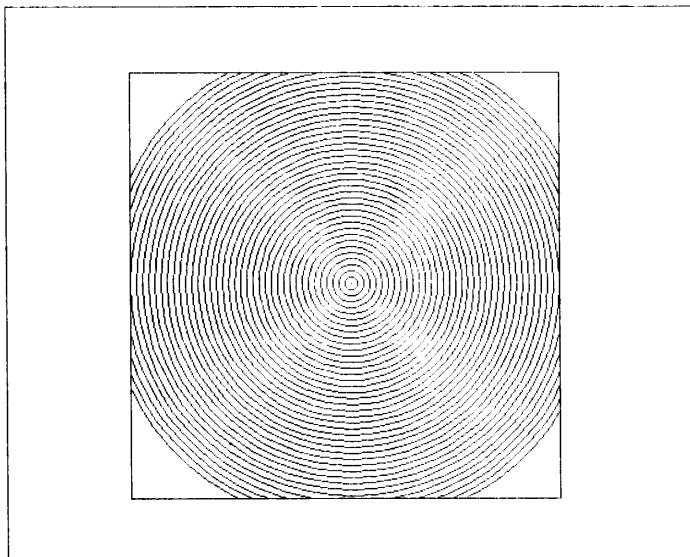

Press continue; the arcs shown in the previous display are erased.

Press continue; the various area fill patterns are displayed.

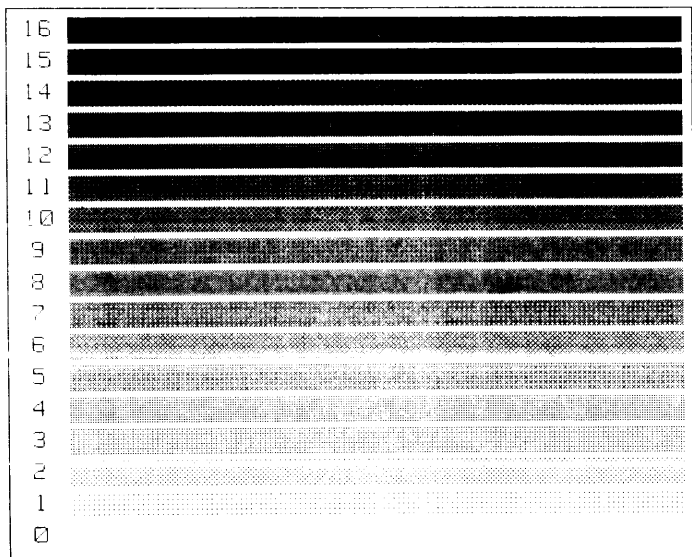

Press continue to select another test.

## R Raster

Press R; a full inverse video alpha raster appears.

Press continue to select another test.

## S Raster With "B" Pattern

Press S; a full inverse video alpha raster with "B" characters appears.

Press continue to select another test.

## T Cursor Types

Press T; a box and a diagonal line are displayed. The full screen crosshair cursor is in the lower left corner.

Press continue; the full screen crosshair cursor moves from the lower left corner to the upper right corner. Then, the small crosshair cursor is displayed.

Press continue; the small blinking underline cursor appears.

Press continue; the rubberband capabilities are shown. See the following photo.

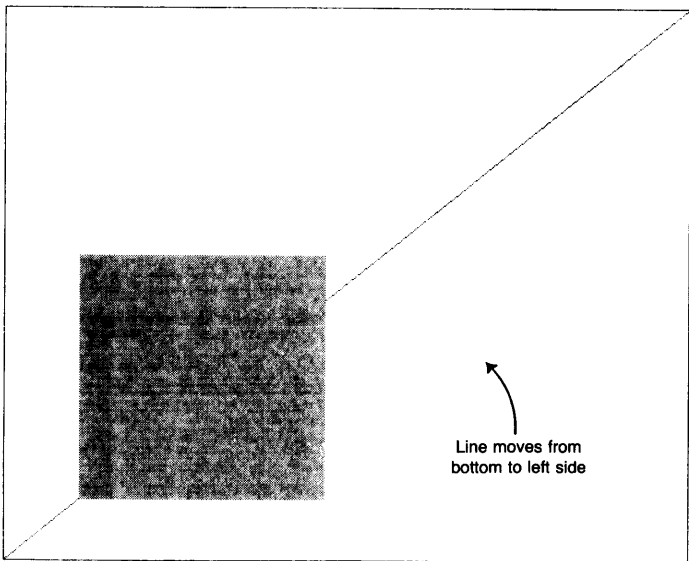

Press continue to select another test.

## **M Graphics Memory Test**

Press M; a full graphics raster is displayed. Graphics is on.

Press continue; the display is blank, graphics is off.

Press continue; graphics is on, the raster is blank and the word "graphics" appears.

Press continue; the graphics memory is cleared, blank display.

Press continue; the graphics memory test is performed.

Press continue to select another test.

## **P Light Pen Test**

Press P; place the pen on the cursor and press the "pick" button. The light pen's field of view value is displayed. The value should be between 10 and 50.

After picking the cursor, a box with a diagonal line appears. The light pen cursor moves from the lower left corner to the upper right corner.

Press continue. With the light pen, place the light pen cursor at each corner of the box starting with corner number 1. Press the light pen "pick" button at each corner.

Press continue to select another test.

## **X Auto Cycle**

This feature allows all the display tests to be run in sequence with or without operator intervention.

Press X; two choices appear.

Press O for an operator supervised test (you have to press continue)

Press A for an automatic test sequence.

# Chapter 6

## Adjustments

### Tools Required

The following tools and equipment are required to align the 98780A:

- #2 Pozidriv Screwdriver (4-inch 10 cm)
- 1/8 inch (3 mm) flat tip screwdriver, 4-inch (10 cm)  
(Recommend HP Part #8710-0033 and 8710-0933)
- Digital voltmeter and probes to measure 800 volts

**Table 6-1**

<b>Adjustment</b>	<b>Procedure on Page</b>
High Voltage	6-3
Intensity	6-3
Focus	6-4
Horizontal Center and Width	6-4
Vertical Center and Height	6-4
Top and Bottom Pincushion	6-5

#### **Assembly Replaced**

CRT/yoke

High Voltage Transformer

A11

A12

#### **Perform**

All adjustments except high voltage (see Table 6-1)

High Voltage, Focus and Intensity

Intensity and Focus

Horizontal Center and Width

Vertical Center and Height

Top and Bottom Pincushion

High Voltage

## Adjustments

All adjustments can be accessed by removing the top cover and the metal top shield. Refer to Figure 6-1 for adjustment locations.

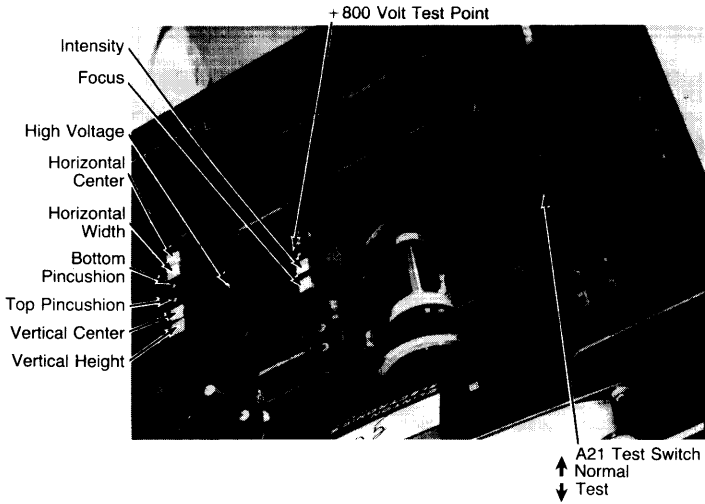

Figure 6-1. Adjustment Locations



---

**Note**

Before performing any adjustment, ensure that all the mainframe power supply voltages are functioning properly.

---

## High Voltage

---

**WARNING**

DO NOT ATTEMPT TO MEASURE THE CRT ANODE VOLTAGE.

---

This adjustment sets the high voltage level for the CRT anode. This voltage can be accurately set by measuring the +800 volts on the A11 assembly. Connect the negative lead of the digital voltmeter to the chassis, and the positive lead to the "800" test point on the A11 assembly (see Figure 5-1).

Adjust the high voltage control on the A12 assembly to set the voltage to 800 volts. The high voltage for the anode should now be at +13 kilovolts.

Perform the intensity and focus adjustments.

## Intensity

This adjustment sets the internal intensity level which determines the range of the external intensity control.

The intensity adjustment procedure is different for different revisions of the A11 Tube Drive Board. Revision C uses the first procedure below. Revisions D and E use the second procedure.

### Revision C Procedure

1. Set the external intensity control on the lower left corner of the CRT bezel to maximum intensity (CW rotation).
2. Adjust the A11 intensity control toward its maximum setting until horizontal retrace lines appear on the display. Adjust the A11 intensity control counter-clockwise until the retrace lines are no longer visible. Note that the brightest retrace line appears at the top of the display.
3. Turn the A11 intensity control an additional ten degrees counter-clockwise (approximately).
4. Adjust the external intensity control for the desired intensity.

### Revision D and E Procedure

1. The CRT tube must be cold in order to properly do the adjustments. It will be acceptably cold if it has not been powered on for more than ten minutes in the last hour, and if it has been off for fifteen minutes immediately prior to starting the adjustment procedure.
2. Connect the positive lead from the voltmeter to the "K" test point on the Drive Board. Connect the negative lead to the "G" test point. Do NOT connect the leads to the voltmeter yet. EXERCISE CAUTION WITH THE BARE ENDS OF THE TEST LEADS. DO NOT ALLOW THEM TO TOUCH EACH OTHER, GROUND, ANY CIRCUITRY, OR YOURSELF.
3. Turn the user intensity pot (located on the lower left of the front of the display) to maximum brightness.
4. Turn on the machine.
5. Within 30 seconds, adjust pot R4 (closest to the back of the unit) until the retrace lines just go away and then an additional ten degrees (approximately).
6. Hook up the other ends of the test leads to the meter.
7. Set the test switch on the A21 board to "TEST" to turn on the full raster.

## 6-4 98780 Adjustments

- Adjust pot R1 (closest to the front of the unit) until the voltmeter reads 46 volts DC.
- Turn off the machine, remove the test leads, install the high voltage cover, and set the test switch to "NORM".
- Turn the machine back on and allow it to warm up for 20 minutes.
- The screen should be reasonably bright with the user intensity pot at maximum, and characters should still be visible with the user intensity pot at minimum. If the characters are not visible at minimum intensity, then increase R1 slightly until they are.
- As a final check, verify that the light pen (if the unit is equipped with one) works at one-half or maximum user intensity. If not, increase R1 slightly until it does.

### Focus

This adjustment sets the CRT focus grid voltage to a value which gives the best overall character focus.

Use the 9845B/C System Exerciser Cartridge (HP Part No. 09845-92041, rev. C), to display the focus pattern. Load the 98780A tests and press F.

Turn the focus control to achieve the best overall focus of the displayed characters. This is usually a trade-off between best corner focus and best center focus.

### Horizontal Center and Width

These adjustments center the raster on the CRT screen and determine the width of the raster.

- Set the A21 test switch to the test position (forward) to display a full white raster.
- Adjust the horizontal center control for equal space between each side of the raster and the CRT bezel.
- Adjust the horizontal width control for a raster width of 236mm.
- Set the test switch to its normal position.

### Vertical Center and Height

These adjustments center the raster vertically and set the height of the raster.

- Set the A21 test switch to the test position (forward) to display a full white raster.
- Adjust the vertical center control for equal spacing between the top and bottom of the raster and the CRT bezel.
- Adjust the vertical height control to set the raster height to 149mm.
- Set the test switch to its normal position.

## Top and Bottom Pincushion

These adjustments correct for pincushion distortion in the raster corners.

- Set the A21 test switch to the test position (forward) to display a full white raster. The following drawings show correct and incorrect pincushion adjustment.
- Adjust the top and bottom controls for straight raster sides.
- Set the test switch to its normal position.

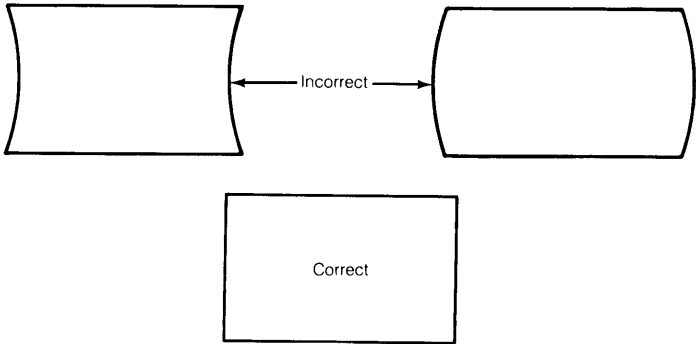



# Chapter 7

## Peripherals

## 7-2 98780 Peripherals

# Chapter 8

## Replacement Parts

### Repair Philosophy

Most 98780A repairs are done by replacing the faulty assembly. The old assembly is returned for repair in some cases (exchange program) and is thrown away in others. In a few cases, a faulty assembly can be repaired to the component level either on-site or at the local field office. This procedure is recommended only when replaceable components are not soldered in or when the probability of inducing further damage in the course of doing the repair is minimal. All components which may be replaced by the CE are listed as level 2 parts under the assembly part number in the parts lists. Other failures should be repaired at the assembly level. All exchange parts are noted as such in the parts lists.

8-2 98780 Replacement Parts

98780 Part Numbers

Assembly Level	Reference Designator	CD	HP Part No.	TQ	Description
1		3	0340-1017	1	High Voltage Cap
1		7	3101-2400	1	Soft Key Assy
1		2	9100-2667	1	Flyback Transformer
1		2	98780-61604	1	Flash-Over Ground Cable
1	A4	1	98780-66504	1	Motherboard Assy
2		4	1251-0472	3	Connector - PC 12 pin
2		4	1251-1115	2	Polarizing key
2		6	1251-1365	1	Connector - PC 44 pin
2		8	1251-2026	2	Connector - PC 36 pin
2		8	1251-2034	1	Connector - PC 20 pin
2		9	1251-2035	3	Connector - PC 30 pin
2		4	1251-2915	5	Connector - PC 50 pin
2		1	1251-3192	2	Connector - 3-pin male
2		4	1251-3195	1	Connector - 4-pin male
2		6	1251-3618	1	Connector - 2-pin male
2		5	1251-4326	1	Connector - 36 pin
2	L1	4	9140-0255	1	Inductor
1	A11	0	98780-66511	1	Tube Drive Assy
1	A12	1	98780-66512	0	Sweep Assy - old version (See 98780-66514)
1	A13	2	98780-66513	1	Power Transistor Assy
2	Q5	8	1853-0305	1	Transistor - 2N5875
2	Q4,6,7	7	1854-0518	3	Transistor - 2N5877
2	Q2	7	1854-0782	1	Transistor
2	Q3	0	1854-0818	1	Transistor
1	A14	3	98780-66514	1	Sweep Assy Exchange part = 98780-69514
1	A21	2	98780-66521	1	Display Logic Assy-Exchange part = 98780-69521
1	A22	3	98780-66522	1	Display Logic Assy-Katakana-Exchange part = 98780-69522
1	A31	4	98780-66531	0	I/O Logic Assy-old version See 98780-66532
1	A32	5	98780-66532	1	I/O Logic Assy
1	A51	8	98780-66551	0	Graphics Logic Assy-old version-See 98780-66552
1	A52	9	98780-66552	1	Graphics Logic Assy-Exchange part = 98780-69552
1		8	98780-67971	0	CRT Yoke Assy-old version
1		9	98780-67972	1	CRT Yoke Assy-new version
1	A12	7	98780-69512	1	Sweep Assy-Exchange-old version
1	A14	9	98780-69514	1	Sweep Assy-Exchange
1	A21	8	98780-69521	1	Display Logic Assy-Exchange
1	A22	9	98780-69522	1	Display Logic Assy-Katakana Exchange
1	A51	4	98780-69551	1	Graphics Assy-Exchange-Old version
1	A52	5	98780-69552	1	Graphics Assy-Exchange
1		4	98775-66504	1	Light Pen Control Assy
1		1	98775-67971	1	Light Pen Assy Exchange part = 98775-69971
1		5	98775-69971	1	Light Pen Assy-Exchange



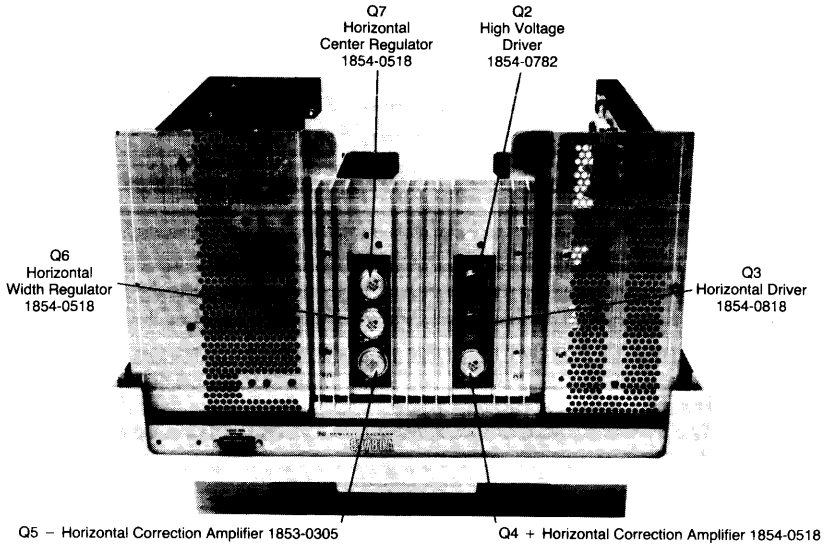

**A13 Heatsink Transistors**

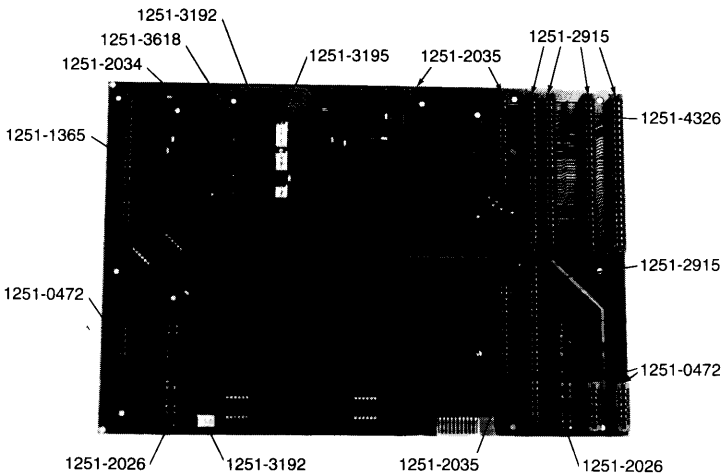

**A4 Motherboard Connectors**

## 8-4 98780 Replacement Parts

# Chapter 9

## Diagrams

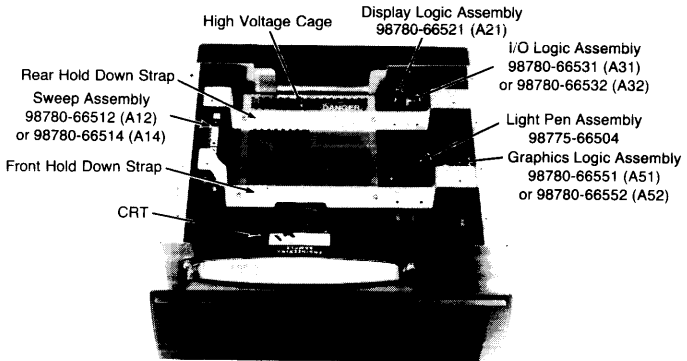

**Assemblies Under the Top Metal Shield**

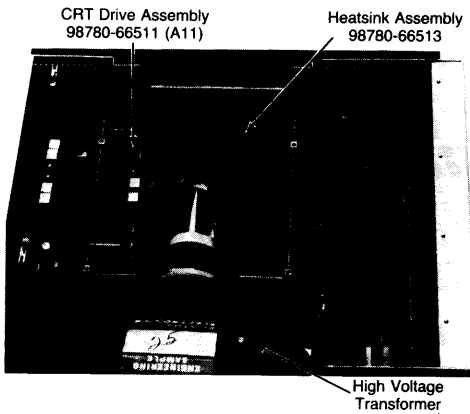

**Assemblies in High Voltage Cage**

9-2 98780 Diagrams

Mnemonic	Description	Mnemonic	Description
AS	Alpha Select	IRH	High Level Interrupt
AVC	Address Valid Clear	LATCH	
B	Blinking Video	LDA	Load Address
BR	Bus Request	NL	New Line
C80	80th Character	NP	New Page
CAS	Column Address Strobe	NW	New Word
CEBG	Chained External Bus Grant	NWA	New Word Address
CSTM	Internal Start Memory Cycle	PBR	Peripheral Bus Request
CUR	Cursor	PEBG	Peripheral External Bus Grant
DIOD	I/O Bus Lines, Internal	PINC	Pincushion Correction
CURS	Cursor Select Line	PSMC	Peripheral Sync. Memory Comp.
DMA EN	Direct Memory Access Enable	RAS	Row Address Select
DMAR	Direct Memory Access Request	RNP	Reset New Page
DSP	Display	SMC	Store Memory Control
EOL	End of Line	SR	Service Request
FLB	Full Line Buffer	STM	Start Memory
G/D	9845 Select Line	SVC	Start Vector Calculation
GINT	Graphics Intensify	TCK	Buffered Mainframe Clock
GVID	Graphics Video	UL	Underline
HGB	Horizontal Graphics Blanking	VB	Vertical Blanking
HLT	Halt	VIDO-3	Video Data Lines
HSYNC	Horizontal Sync Signal	VSYNC	Vertical Sync Signal
IDA	Instruction, Data, Address	WE	Write Enable Lines
IE	Interrupt Enable		
INCM	Increment Memory		
INCS	Increment Scan Address		
INIT	Initialize		
INT	Interrupt		
INV	Inverse Video		
I/O	I/O Data Bus Lines		

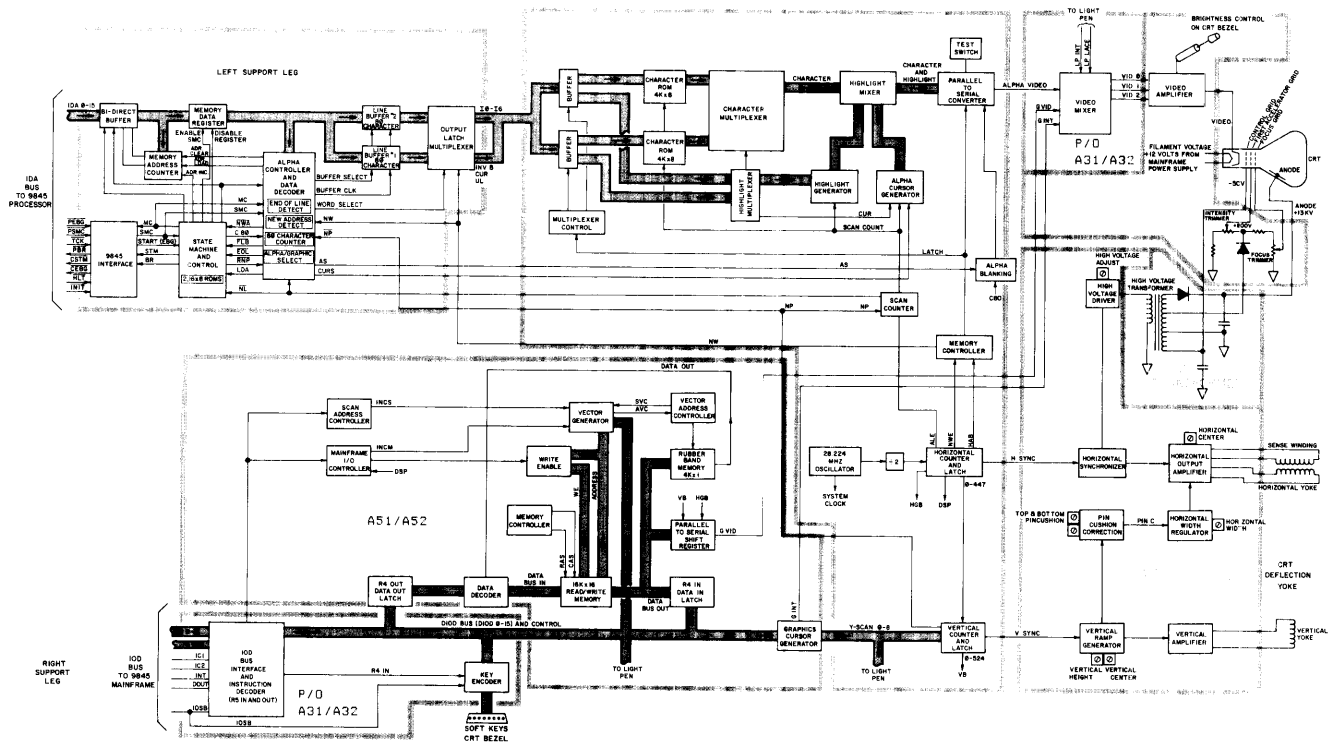

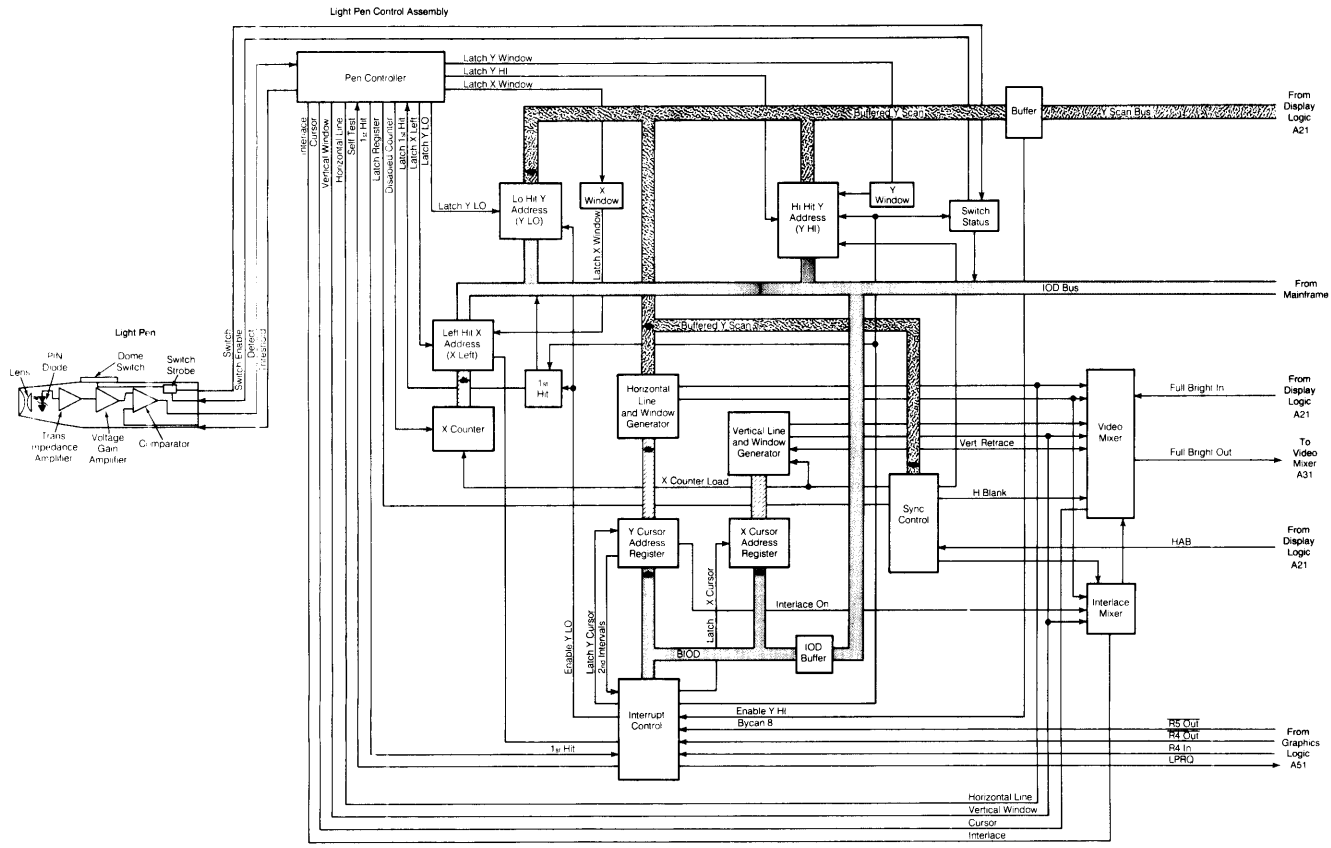

# Chapter 10

## Reference





# Chapter 11

## Service Notes

